

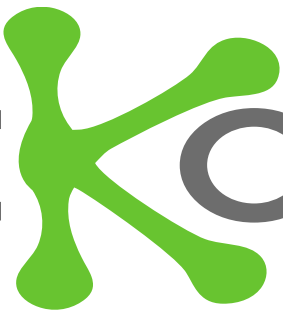



gecko  

Connect with Confidence

HARWIN

Gecko-MT High-Reliability Connectors

What is Gecko-MT?

The **SMALLEST,**
LIGHTEST,
MIXED-LAYOUT
Connector

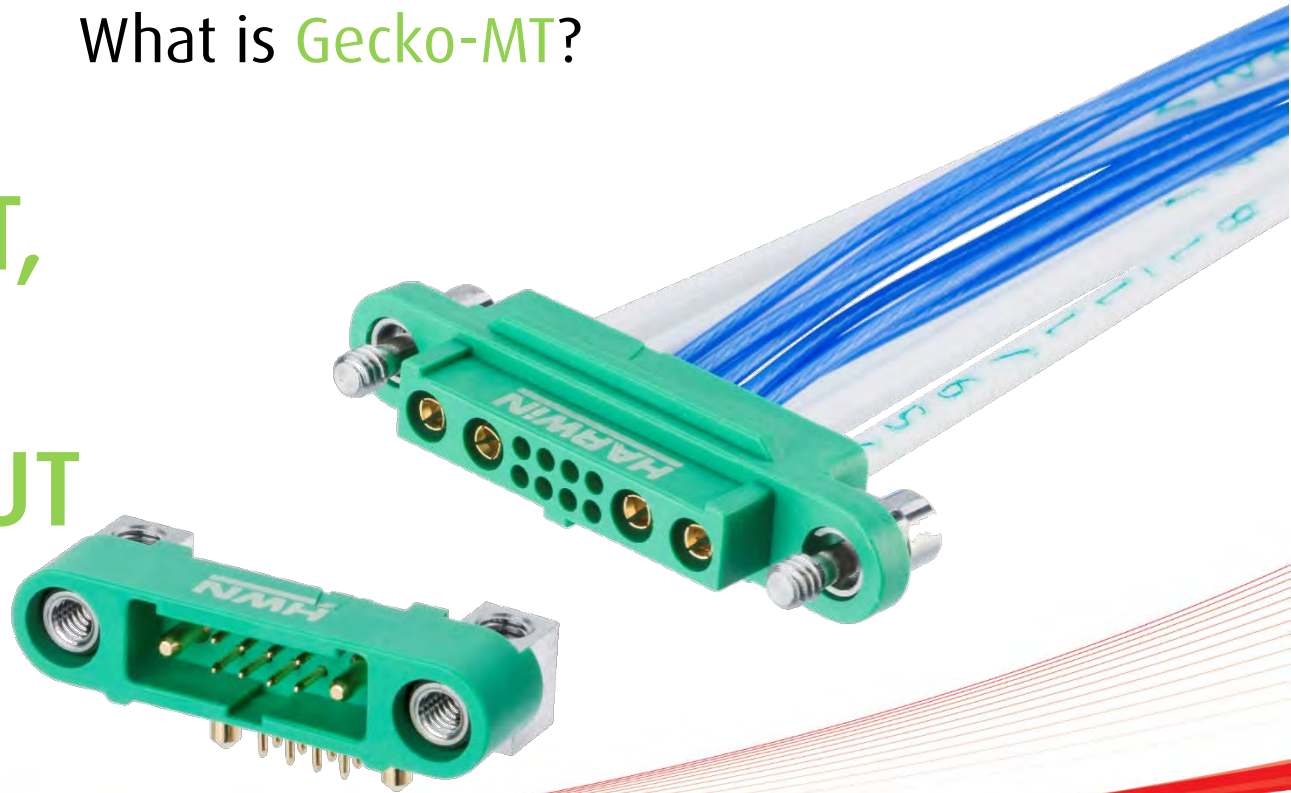

HARWIN

Gecko-MT is the latest evolution of the Gecko product. The Screw-Lok connector system (with robust stainless steel screw-loks for simpler access, stronger fixings, and panel mount options) has been enhanced with additional power contacts, rated at 10A.

Configurations available are:

- 1 power, 8 signal, 1 power
- 2 power, 8 signal, 2 power

Gecko-MT High-Reliability Connectors

The **Heart** of the connector

- 26AWG & 28-32AWG – Signal
- 18AWG Power

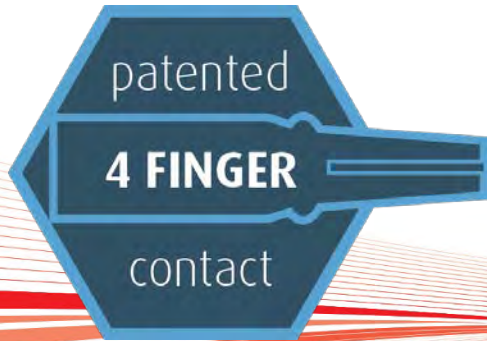

HARWIN

Gecko-MT is designed to help address the market trend to improving SWaPC – increase miniaturization, decrease weight, add or improve power options, and either lower cost or get the best possible value for cost.

These factors are big drivers in every industry using electronics – but are most prevalent in avionics and space, defense and motorsport industries. Addressing these factors on every component frees up additional size/weight/funds for additional or improved functions.

Gecko-MT High-Reliability Connectors

What is SWaPC?

SIZE, WEIGHT
AND POWER
AND COST



HARWIN

Gecko-MT is designed to help address the market trend to improving SWaPC – increase miniaturization, decrease weight, add or improve power options, and either lower cost or get the best possible value for cost.

These factors are big drivers in every industry using electronics – but are most prevalent in avionics and space, defense and motorsport industries. Addressing these factors on every component frees up additional size/weight/funds for additional or improved functions.

Gecko-MT High-Reliability Connectors

Size – Pin Spacing

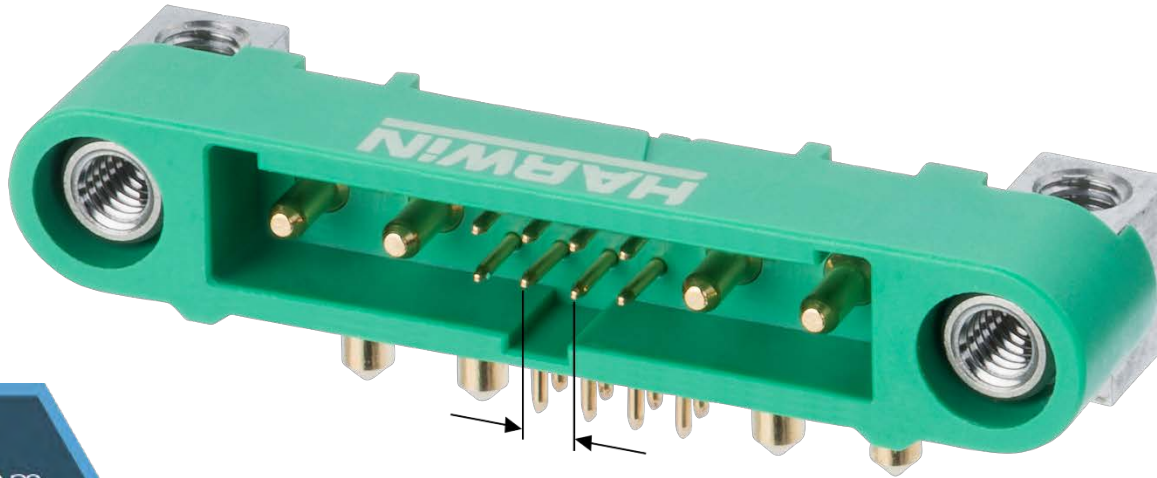

HARWIN

The 1.25mm pitch metric pin spacing from the rest of the Gecko range is utilized on the Gecko-MT range for the signal contacts. The pin spacing is 1.25mm pin both rows and columns, and is also the same on the PCB throughboard tails.

Gecko-MT High-Reliability Connectors

Size **savings** over other products

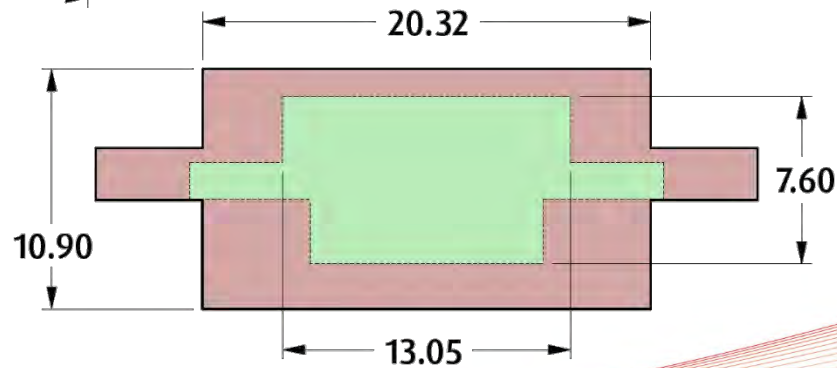
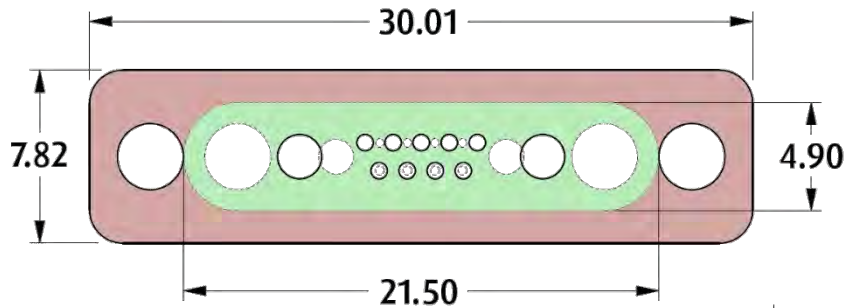

Green
Gecko-SL

Red
Micro-D

HARWIN

Gecko-MT provides major space savings over the next main comparable product, Micro-D with power combinations. The decreased size (demonstrated here with female cable connectors) is applicable across the connector range. The reduced PCB footprint and cable connector volume means this product can be considered in circumstances where Micro-D wouldn't fit.

Gecko-MT High-Reliability Connectors

Weight comparison

ONE 2+8+2
GECKO-MT
weighs less than
a playing
CARD



HARWIN

With an all-plastic housing construction, Gecko-MT keeps the weight penalty down to a minimum. Compared to a standard size playing card at 1.8g, a female PCB connector in 2+8+2 configuration weighs in at just 1.53g.

Gecko-MT High-Reliability Connectors

Power

What are your
power
requirements?

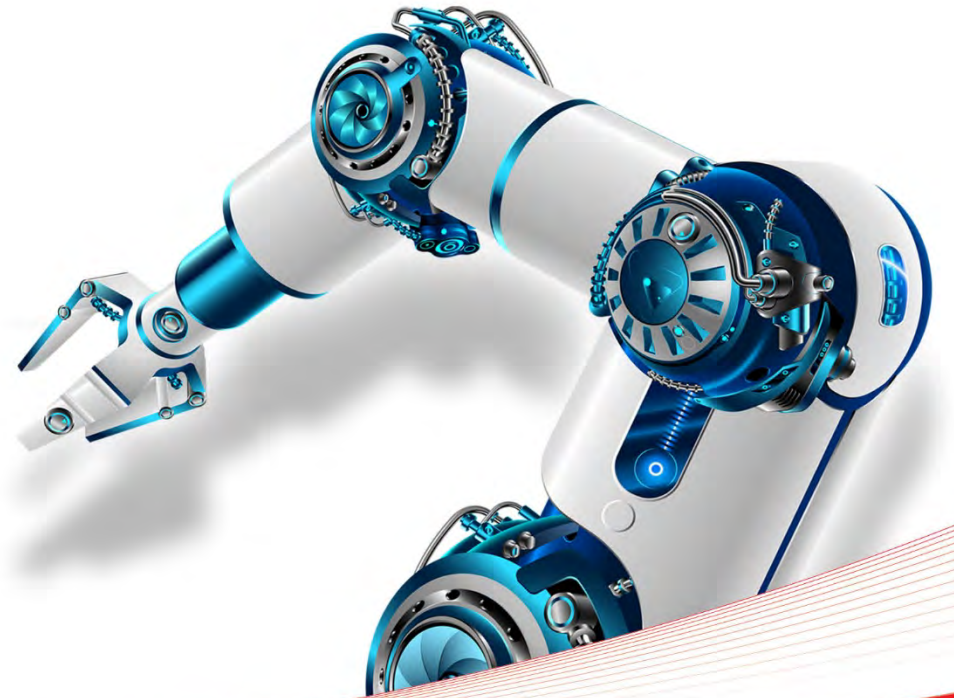

HARWIN

At 2.8A per signal contact individually, 2A simultaneously, and 10A for the power contacts, Gecko-MT is comparable to other combination connectors in the micro-miniature range.

Combining power and signal into one connector delivers power to mechanical movement components and powered PCBs, as well as maintaining the signal current along parallel paths, making circuits and cabling simpler and easier to track.

Gecko-MT High-Reliability Connectors

Cost comparison



HARWIN

The cost of products are easily compared to the cost of weight. For each kilogram taken into space, for example, a CubeSat manufacturer may be charged 50,000 euros. A single bottle of water can cost from \$9,000 to \$43,000 to get to the International Space Station. Costs will be less on a UAV, but there is still an associated cost in fuel requirement to get the weight to leave the ground.

Less weight, less fuel, less cost.

Gecko-MT High-Reliability Connectors

Performance – Electrical Specifications

Current Rating	10A Power 2A Signal
Contact Resistance	20mΩ
Insulation Resistance	1000MΩ



HARWIN

10A power contacts provides additional flexibility to the board and cable layouts, and may even replace the requirement for a separate power connector. This gives significant savings for the SWaPC equation.

Gecko-MT High-Reliability Connectors

Shock & Vibration resistant

Vibration	20g No discontinuity greater than 1µs
Shock	100g 6m/s Z axis No discontinuity greater than 1µs
Mating Cycles	1,000



HARWIN

Given the top end target applications for these connectors, vibration and shock levels are key to the performance of the Gecko-MT connector:

- Vibration at the take-off stage of a jet plane;
- Rocket and payload / satellite launch shock and continued vibration until earth orbit;
- Motorsport with high frequency bumps and vibration levels, potentially for multiple hours.

Gecko-MT High-Reliability Connectors

Wide Operating Temperature

Operating Temperatures	-65°C to +150°C
Salt Spray	48 Hours
Humidity	65/150/56 days at 95% Relative Humidity

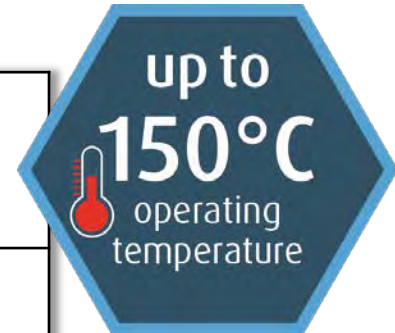

HARWIN

Typical applications that would benefit from these levels of temperature include:

- Down-hole drilling (in the oil & gas industries) – these drills get very hot, and can be difficult to adequately cool;
- Satellites – with repeated cycles of extreme darkness and unfiltered sunlight;
- UAVs – flight operations at high-altitudes and associated low temperatures.

Gecko-MT High-Reliability Connectors

Low Outgassing

NASA Accepted Levels	Gecko Material Levels
1.0% or Less TML (Total Mass Lost)	0.68% TML
0.10% or Less CVCM (Collected Volatile Condensable Materials)	0.01% CVCM
1.0% or less of the original mass	0.26% WVR (Water Vapor Recovered)



HARWIN

Outgassing (sometimes called offgassing) is the release of gas that was dissolved, trapped, frozen, or absorbed in material. Outgassing can include sublimation and evaporation (phase transitions of a substance into a gas), desorption, seepage from cracks or internal volumes, and gaseous products of slow chemical reactions. All can potentially introduce contaminants into a previously clean product.

The levels achieved by Gecko meet both NASA and ESA (European Space Agency) required specifications.

Gecko-MT High-Reliability Connectors

PCB mounted variants



HARWIN

The PCB versions of Gecko-MT feature Female vertical connectors, and Male horizontal connectors. The connectors are designed for Throughboard mounting, and there are variations for board-mount fixing in both genders.

Board-mount fixing nuts and bolts are available to purchase separately.

Gecko-MT High-Reliability Connectors

Cable mounted variants



The cable versions of Gecko-MT are also available in both genders, and feature rear backpotting cavities. Tooling for customer crimping is available, and instruction sheets are published to assist with the crimping process.

Cable assemblies can be quoted on request. Contact the Technical Team on technical@harwin.com for further assistance.

Gecko-MT High-Reliability Connectors

Cable mounted variants



HARWIN

To complete the Gecko-MT range, the connectors have been specifically designed to fit the existing 16-contact and 26-contact Gecko-SL metal backshells. This enables fully shielded cable assembly construction, with the addition of metal braiding secured around the backshells.

Gecko-MT High-Reliability Connectors

Screw-Lok fixing hardware



HARWIN

The captive screws with hex socket heads prevent slipping during assembly. The design of these captive screws allows for 'Mate before Lock' - connectors can be fully mated before the screws need to be engaged. This provides for faster and easier assembly.

Reverse Fix options are available for all versions of board and cable connectors, providing board-to-cable combinations with a choice of either Male (standard fix) or Female (reverse fix) on the PCB.

Gecko-MT High-Reliability Connectors

Other physical features

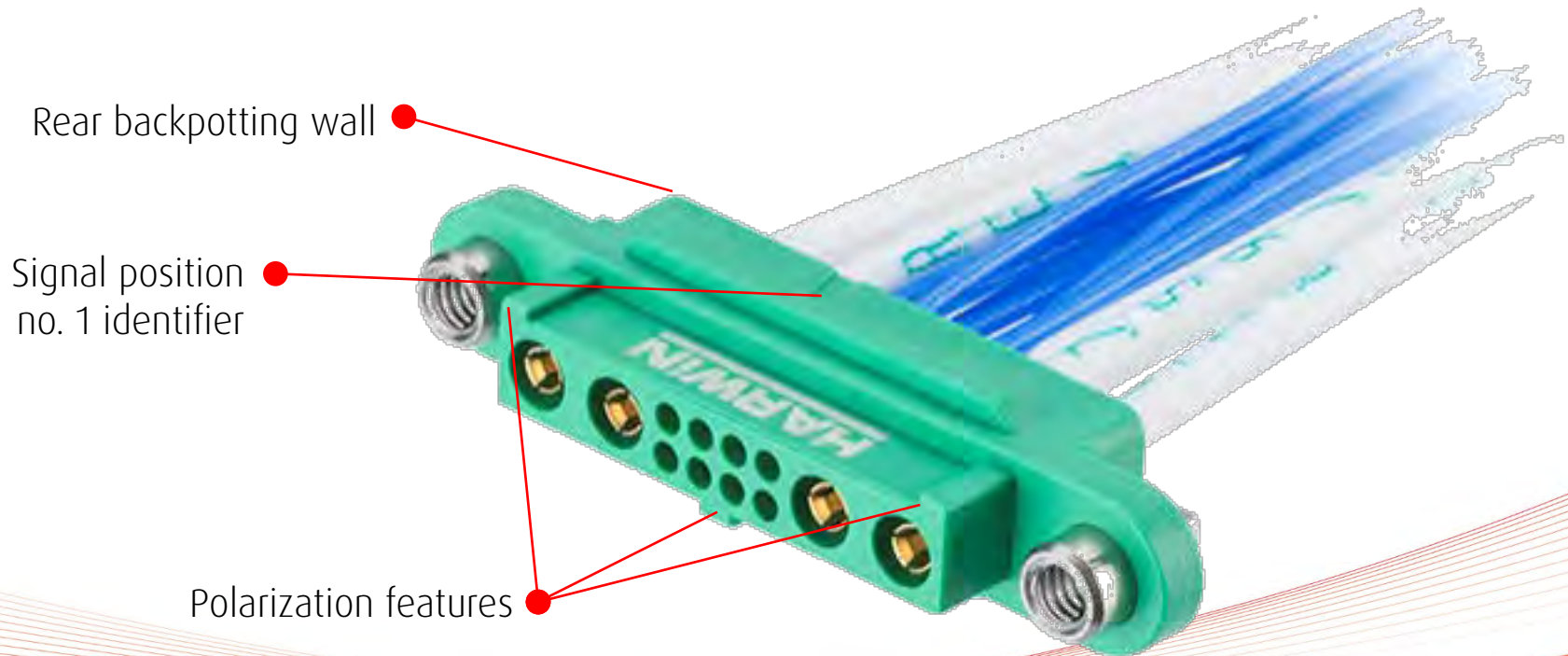

HARWIN

All the best features from the Gecko-SL series are retained on the Gecko-MT:

- Backpotting walls for additional strain relief resin;
- Position number 1 identifier on the signal pins (see the [Component Specification](#) for full pin numbering);
- 3 polarization features to assist easy mating without the possibility of error.

Gecko-MT High-Reliability Connectors

Related products

- Dummy signal contacts
- Crimp and insertion tooling
- Cable assembly facility



HARWIN

A full complement of tooling and associated instruction sheets are available for the Gecko-MT range. Or Harwin can carry the strain, and supply a complete cable assembly service to your requirements.

Gecko-MT High-Reliability Connectors

Applications & Markets



HARWIN

Many markets have a requirement for rugged, high-reliability connectors, with the additional requirements for miniature size, minimal weight restrictions and added power options. Gecko-MT delivers in these industries:

- UAVs
- Motorsport
- CubeSats
- Avionics
- Oil & Gas

Gecko-MT: Connect with **Confidence**

The **SMALLEST, LIGHTEST, MIXED-LAYOUT** Connector

Tested to extreme G-force and temperature, Engineers will find it ideal for applications that must not fail.



HARWIN

If you like this product, try...

Datamate - 2.00mm Pitch

 **M300** - 3.00mm Pitch

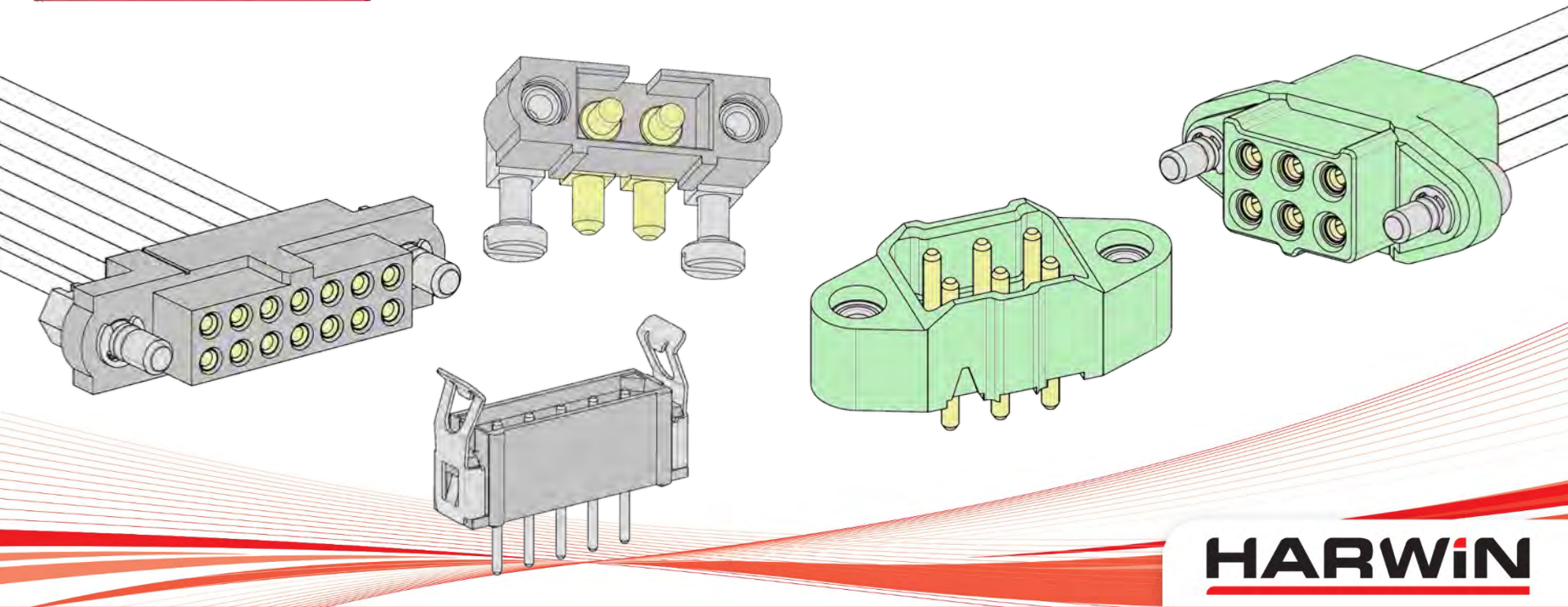

HARWIN

- 3A per signal, up to 40A per power contact
- Jackscrew or latching system for strain relief
- Resists Vibration to 10G and Shock to 100G
- Temperature range -55 deg C to +125 deg C
- PCB connectors in Throughboard or SMT, Cable options

- Up to 10A per contact
- Jackscrew fixing system for strain relief
- Resists Vibration to 10G and Shock to 100G
- Temperature range -65 deg C to +175 deg C
- Vertical and Cable options

Happy to Help

Contact our technical support team

➤ Email us



Get CAD models for FREE

➤ Download here

Request evaluation samples

➤ Click here



HARWIN